



SG-3000 Series Generator Sets

One step ahead in genset technology



- Efficiency
- Reliability
- Flexibility
- Easy to operate





Content

<i>Introduction</i>	3
<i>SG-3000 Series Generator Sets</i>	4
<i>SG+ Controller</i>	5
<i>SG-3000 product range</i>	6
<i>Specifications</i>	7

Introduction



Energy consumption and reliability are significant contributors to the total life cycle cost of a genset unit.

For years, Thermo King has been leading the challenge of making more efficient, reliable units available to customers in the five continents.

The SG-3000 genset is the result of years of experience in designing and maintaining units for different climatic and operational conditions, and benefits from the most advanced technologies and a highly reliable design.

This translates into a low emission, reliable source of electric power for refrigerated containers, no matter the ambient temperature or the load. The SG-3000 product range offers different mounting options for containers, whether they are stationary or travel by rail or road.



Power to start refrigeration units (regardless of age or type) and excess power capacity for starting power over the life of the genset.

SG-3000 Series Generator Sets

Efficiency: *EcoPower™*

Enhanced operation mode allows highly efficient engine management for dramatic fuel savings, low emissions and extremely accurate, load-independent voltage regulation.

Reliability

The result of years of experience on the ground and thoughtfully tested components supported by Advanced Diagnostic, Auto restart function, global positioning and fuel consumption monitoring capability.

Flexibility

Specifically designed for reefer applications, available in 3 models for **Clip-On, Center-Mount or Side-Mount**.

Easy to operate

User-friendly interface featuring a multi language, high resolution controller interface ensuring that the unit is operated properly, no matter where in the world.

Convenient

Extremely low fuel consumption and extended maintenance periods result consistently in lower life-cycle costs.

Future-proof

Latest engine, exciting technologies and Advanced Telematics options make the SG-3000 a sound and future-proof investment.



<i>Features</i>	<i>Benefits</i>
Steel frame with extensive 8 step cleaning finished in powder-coated stainless steel and zinc dichromate and e-coated copper tube and aluminum fin radiator	Provides extended corrosion resistance in harsh environments
The exclusive generator design has been continuously improved since being implemented into the product line in the early 1970's	Assures the highest reliability level
Advanced engine technology featuring an innovative high pressure injection pump, meeting US EPA (Environmental Protection Agency) Interim Tier IV operation, required from January 2008, using an enhanced operation mode	A guarantee of a long term investment
Exclusive alternator design offers significant advantages over traditional alternators	Increased reliability and power efficiency
Patented cyclonic media air cleaner and ThermoKing patented spin-on, self-evacuating fuel filter	Improved filtering capacity for a longer engine life and extended maintenance intervals
New exiter design featuring a simplified architecture	Fewer components, easier diagnostics, higher reliability

SG+: the Next Generation of Microprocessor Controllers

Improved engine management

Ability to operate genset at variable speeds for reduced fuel consumption and emissions.

User-friendly interface

A 4-lines, clear display allows full-message text for clear and immediate understanding of the unit status, settings and alarm messages. Eliminates the need for acronyms and code tables while maintaining the same efficient menu structure of the previous model.

Multiple language support

The extended memory and advanced menu system supports multiple languages. This not only applies to the alarms, but to the entire menu navigation process, making SG+ the ideal interface between the SG-3000 and the operator.

Advanced diagnostics

Simplified pre-trip components test function and advanced self-checking diagnostic capabilities, including manual function tests and assures trouble-free operation.

Fuel monitoring capability

Full download of the fuel level related data is available by connecting to the download port on the front of the control box. Keeps track of fuel consumption and detect abnormal situations.

Auto restart feature

Allows automatic re-start minimising cargo losses and providing maximum protection for the shipment.

Automatic preheating of engine and delayed voltage output

Extends the life of the unit by ensuring proper operation prior to the full load being applied and prevents engine/ alternator damage from cold-starting full reefer loads.

Enhanced interfacing capability

The Software updates direct down-load and future performance enhancements support, and offers interfacing with advanced telematics options and communication systems making the SG+ a future-proof controller for years to come.

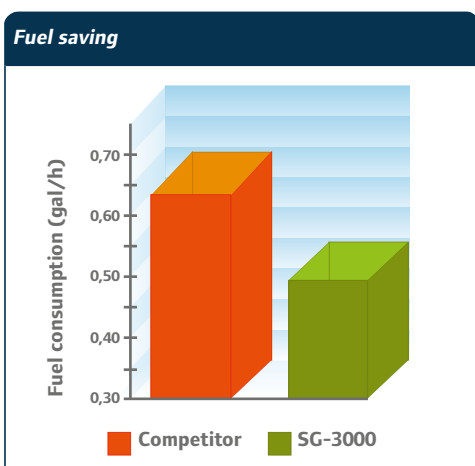

SG-3000 with EcoPower™ option: the new reference in Fuel saving

Hardware and software enhancements and Thermo King patented technology are at the foundation of the record performances of the SG-3000.

More than 20% fuel savings, when compared with competitors' gensets today, using enhanced operation mode.

SG-3000: Product range

Clip it on, plug it in. SGCO-3000

Streamlined dimensions and serviceability are key features of the aerodynamic clip-on gen-set. This fully self-contained unit mounts to the container's corner castings with quick-disconnect fasteners or optional header pin mounting. It's a power plant that can go anywhere the container goes and is ideal for railcar and double stacking. It includes a built-in 125 gallon "true draw" fuel tank.

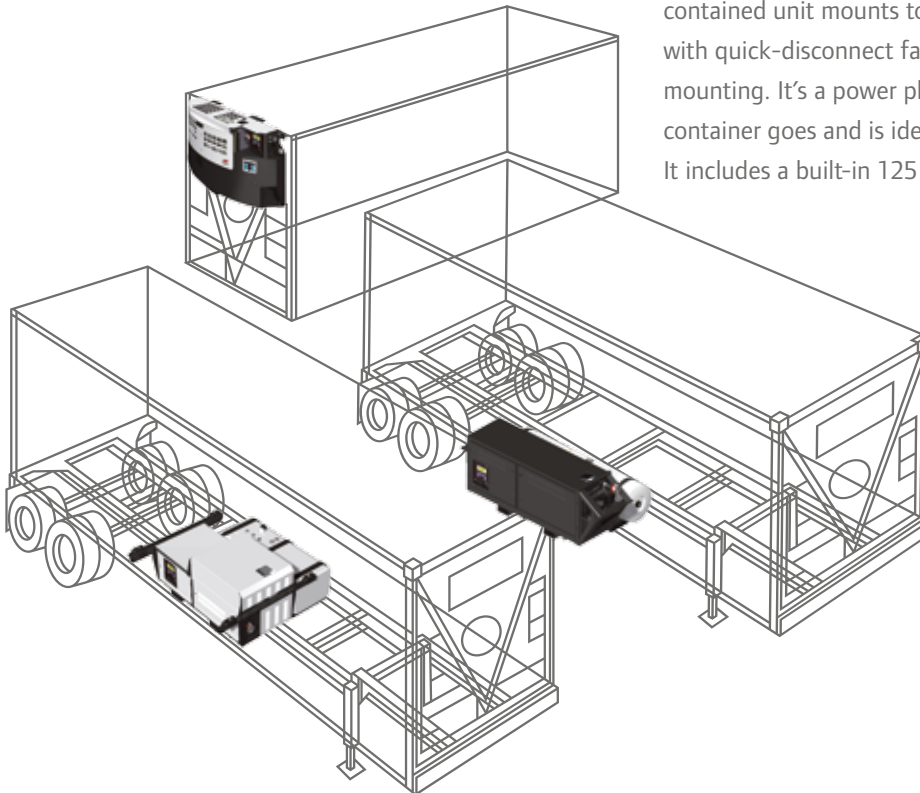

6

Underslung Configuration SGCM-3000

The centermount model mounts under the centre of the container chassis between the I-beams to allow for maximum road clearance and even weight distribution. Built-in quick disconnect mounting hardware allows it to be easily mounted and removed. It has an integral 80 gallon fuel tank.

Underslung Configuration SGSM-3000

This model is designed for applications requiring under mounting on the side of a container chassis rather than in the centre. It includes a 75 gallon fuel tank and optional quick connect/disconnect mounting arms to further simplify application.



Thermo King patented
SGCO Dual-Clamp Mount

Specifications

SG-3000 SERIES GENERATOR SET	
Engine	TK Diesel engine compliant with Interim Tier 4 2008 requirements
Fuel Type	No.2 Diesel (under normal conditions) No.1 Diesel (cold weather fuel)
Rotational speed	1890+/-10 RPM 1560 + 10-0 RPM
Generator	460/230 Vac, 3 Phase, 60Hz
Output Power	15 kW
Apparent Power	18.75 kVA
Rotational speed	1800 RPM
Electrical System	SG+ microprocessor controller
Battery	12V, 925 CCA at -18°C (0°F)
Fuel Tank	Included in all models
SG Clip-On SG Centre-mount SG Side-mount	125 gal (473 litres) 80 gal or 50 gal (302 litres or 198 litres) 75 gal (283 litres) Round steel tank

Specifications are subject to change



SGSM-3000

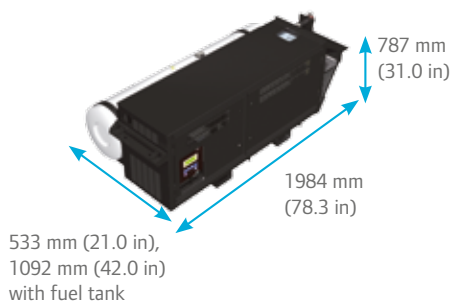

Weight:
678 kg (1495 lbs) - Total Weight, including Gen Set, oil, coolant, dry fuel tank and battery.

SGCO-3000

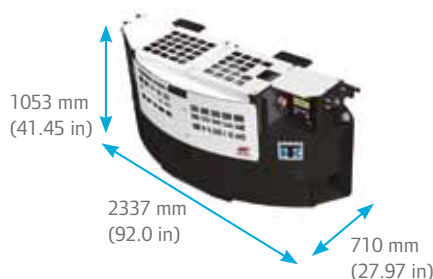

Weight:
818 kg (1804 lbs) - Total Weight, including Gen Set, oil, coolant, dry fuel tank and battery. Genset to be provided with decal indicating gross weight inclusive of fuel.

SGCM-3000

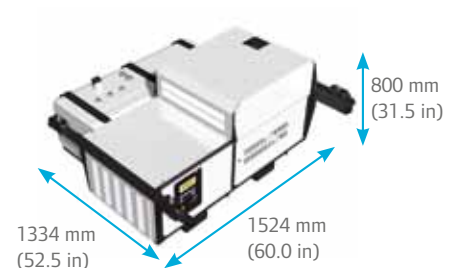

Weight:
671 kg (1480 lbs) - Total Weight, including Gen Set, oil, coolant, dry fuel tank and battery. Genset to be provided with decal indicating gross weight inclusive of fuel.

The importance of always using Thermo King Spare Parts

Genuine Thermo King replacement parts are proven time after time to beat the competition in side-by-side testing. Engineered to provide optimal performance and maximum life, Thermo King service parts protect your investment and provide you peace of mind and confidence on the road. Insist on Genuine Thermo King parts, every time !

Warranty Summary

Terms of the Thermo King Warranty are available on request from your local Thermo King Dealer. Please reference document TK50048 for the Thermo King Container unit warranty.



Thermo King Corporation, a business of Ingersoll Rand – the world leader in creating and sustaining safe, comfortable and energy efficient environments – was founded in 1938 and manufactures transport temperature control systems for a variety of mobile applications, including trailers, truck bodies, buses, shipboard containers and railway cars. The company operates 10 manufacturing facilities and 17 parts distribution centers worldwide. Sales and service is provided by a global dealer network of 865 independently owned companies in 75 countries.

europe.thermoking.com thermoking.com ingersollrand.com

