



T Series

The most reliable HVAC system for transit is now better than ever.



TRANE
TECHNOLOGIES™



High performance and reliability for more than 30 years. *T-Series: The HVAC design that changed an industry.*



Low life cycle costs

Performance proven components provide long service life and minimum maintenance for low life cycle costs.

Lightweight

Lightweight all aluminum frame, blowers, coil headers and compressor reduce bus stress and fuel consumption.

Easy to service

Convenient service access to all major components. Simplified electrical troubleshooting with microprocessor controls. Removable access panels and a convenient rear window location provide easy access to unit components for repairs or maintenance.

Same major components and options across platform.

T Series units have many of the same internal components in the electrical and refrigeration systems, assuring a readily available supply of parts and parts interchangeability to lower costs and minimize downtime.

Easy to install

T Series units are easy to install and service because of the compact, one-piece design.

Proven dependability

You know you're getting a dependable, reliable bus air conditioning and heating system that can lower your operating and maintenance costs and keep your bus riders cool.

Best Value, Best Performance.



T-Series All-Electric HVAC Options

Help drive energy efficiency and Sustainability in your organization.

TEA Series



TE Series

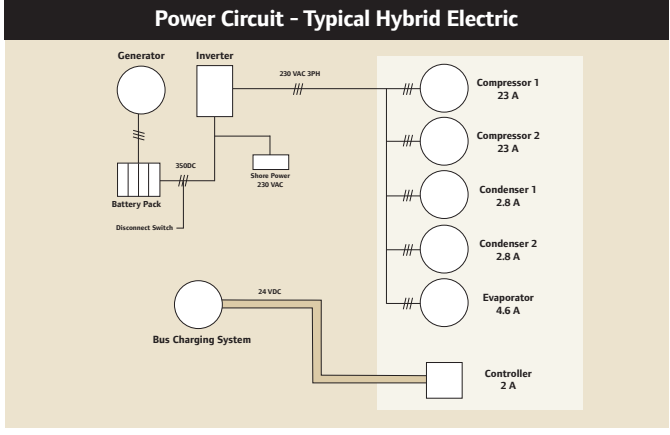
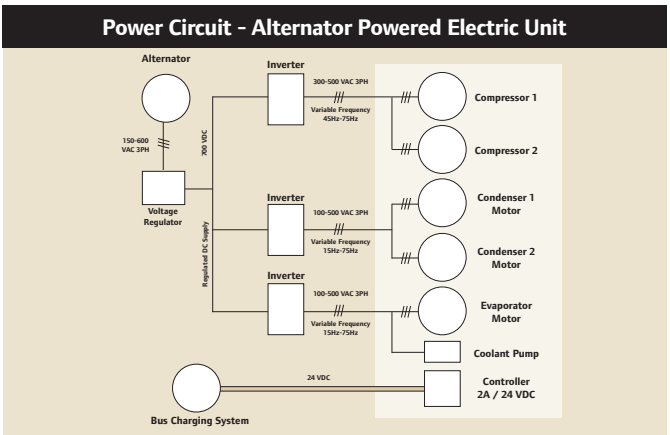

For use on standard diesel engine-driven buses.

For use on hybrid electric and all-electric buses.



Power Electronics for Alternator Powered All-Electric HVAC

For complete All-Electric specifications, see your local Thermo King dealer or call 952-887-2241



T Series Specifications

Evaporator Airflow* *

0 mm (0 in.) water column
external static pressure
High speed fan
-3814 m³/hr (2250 cfm)
Low speed fan
-2366 m³/hr (1400 cfm)

* *Consult factory for optional airflow on high speed or low speed fan operation.

Performance Data

System net cooling capacity with 35°C (95°F) ambient, and 26.7°C (80°F) db, 19.5°C (67°F) wb evaporator return air (50% RH):

Refrigerant HFC R-407c*

| CompressorNet System Capacity | | | | |
|-------------------------------|---------|---------|----|--|
| RPM | Btu/hr | KCal/hr | HP | |
| 1000 | 66,700 | 16,808 | 7 | |
| 1800 | 88,400 | 22,277 | 15 | |
| 2400 | 97,300 | 24,520 | 21 | |
| 2800 | 101,000 | 25,452 | 24 | |

Refrigerant HFC-134a*

| CompressorNet System Capacity | | | | |
|-------------------------------|--------|---------|----|--|
| RPM | Btu/hr | KCal/hr | HP | |
| 1000 | 45,700 | 11,516 | 6 | |
| 1800 | 73,600 | 18,547 | 12 | |
| 2400 | 83,900 | 21,143 | 15 | |
| 2800 | 86,000 | 21,672 | 18 | |

* Nominal cooling system capacities shown above may vary depending upon the specific T Series unit model (frame size) selected. Consult factory for more specific performance data for your application.

System Heating Capacity

24,696 KCal/hr (98,000 Btu/hr)
@ 8 GPM & 160°F water

Electric Power Requirements

AT 27V dc
High speed fan: 106 amps (high speed evaporator and condenser fans)
Power source: Bus alternator or Thermo King batteryless alternator (options below)

Unit Operation W/Driver Mode Switch

Reheat: Compressor clutch continuously engaged, boost pump and water control valve cycling is controlled by thermostat.

Cool: Compressor clutch cycles On/Off on demand of thermostat.

Vent: Evaporator fan operation only.

Heat: Boost pump and water control valve cycle on demand of thermostat. Compressor clutch off.



Add Thermo King's T-Series HVAC system to your specification today.



Thermo King offers system diversity to fit your individual requirements.

Unmatched versatility to meet customer specifications.

2 Refrigerant Options

- R134a
- R407C

3 Motor Options

- Brushless
- Wound Field
- Permanent Magnet

3 Compressor Options

- X426/X430
- S391 Screw
- S616 Screw

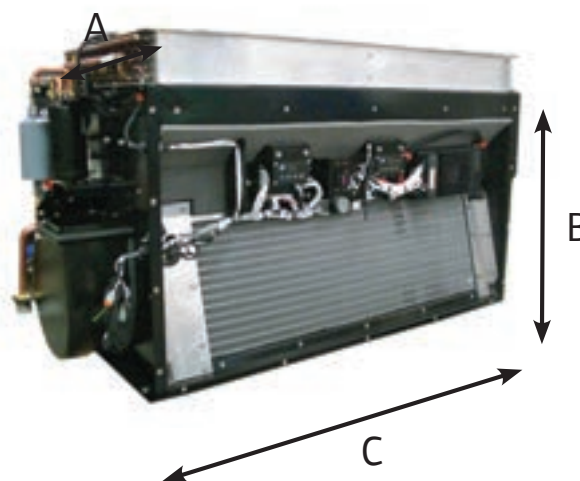

| Unit | A (Depth) | B (Height) | C (Width) | Weight |
|------|-------------------|-------------------|--------------------|---------------------|
| T 14 | 683 mm (26.9") | 902 mm (35.5") | 1636 mm (64.4") | 168 KG (370 lbs) |
| T 15 | 658 mm (25.9") | 963 mm (37.9") | 1618 mm (64.4") | 173 KG (380 lbs) |

The best solution available for CNG Rear Mount applications.



T-Series Standard Features

Why pay for more than you want. Thermo King provides standard features designed to meet your needs.

Thermo King's IntelligAIRE III Control System Delivers Industry-Leading Capability with Unmatched Ease-of-Use

- ✓ Multiple zones can be controlled using identical expansion modules via CAN network and interconnected software
- ✓ Expanded CAN communication capability to plug directly into the vehicle's J1939 network
- ✓ Operator-friendly display and pressure modules for improved control and diagnostics

Four simple modules remove complexity for operators and technicians.



Display Module



Pressure Display Module



Main Module



IO Module



High Performance R-407C

- Environmentally safe alternative that provides more BTUs of cooling per HP used

R-134a Refrigerant

- Environmentally-friendly solution



The Thermo King X430 Compressor

- Engineered exclusively for transport applications
- Built for extended service life
- Field repairable

Additional Standard Features

Evaporator fan motor

- Heavy-duty, double shafted industrial permanent magnetic motor with replaceable bearings and brushes
- 27V, 1.15 hp, 1700 rpm (high speed)
- Drives two large, high airflow, forward curved, centrifugal blowers

Condenser fan motors

- Two, heavy-duty, industrial permanent magnet motors with replaceable bearings and brushes
- 27V, .75 hp, 1900 rpm (high speed)
- Each motor drives a 457 mm (18 in.) diameter axial flow fan



T-Series Optional Features

Take control of your operating costs with these cost-saving options available only from Thermo King.

Thermo King Brushless Motors



114-LB. WEIGHT REDUCTION FOR IMPROVED FUEL ECONOMY!

Designed Specifically for Mobile Air Conditioning

Lower Your Operating Costs

- Eliminates High Brush Maintenance Costs
- Fewer Parts to Maintain and Replace - Electronic Package is Integral to Motors, Eliminating External Controllers, Harnesses, Terminals and Studs for Lower Costs
- Advanced Diagnostics Provide Failure Mode Indication



IntelligAIRE III® Electronic Pressure Display Module

- Touchpad displays four different pressure readings
- Simplifies problem diagnosis and pre-trip inspections



S391/S616 Screw Compressors

- Exclusive oil management system for increased reliability
- Fewer moving parts than reciprocating compressors
- Lower noise levels and vibration than reciprocating compressors
- Programmable capacity control for fuel savings



Electronic Energy Management System

- Provides fuel savings with X426, X430 and X640 reciprocating compressors
- Programmable electronic capacity control reduces the parasitic load on the engine



High Performance Clutch

- Long-life sealed bearing
- More torque for heavy-duty applications
- Extended maintenance intervals

Additional Optional Features

- Wound field condenser & evaporator fan motors
- Modulating water valve
- 125 amp, 27V dc batteryless alternator (independently powers fan motors and controls)



Thermo King – by Trane Technologies (NYSE: TT), a global climate innovator – is a worldwide leader in sustainable transport temperature control solutions. Thermo King has been providing transport temperature control solutions for a variety of applications, including trailers, truck bodies, buses, air, shipboard containers and railway cars since 1938. For more information, visit thermoking.com or tranetechnologies.com.

