

SG-5000 SERIES

— high performance generator set range
for marine containers —

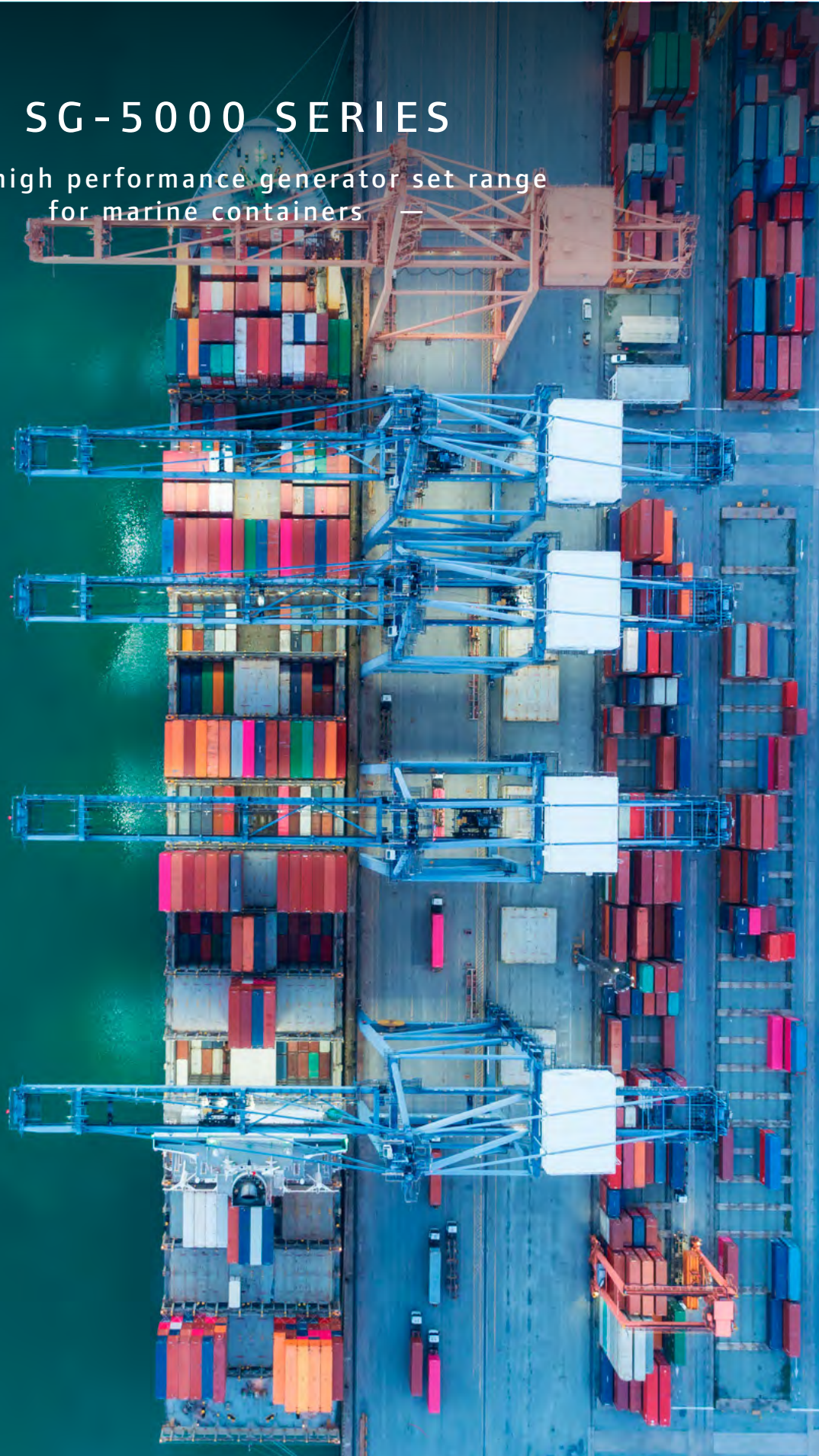

Protecting cold chain integrity



SG-5000 YOUR INDEPENDENT POWER SOURCE

Temperature sensitive cargoes require independently powered units that keep running whatever conditions, temperatures or delays they have to contend with. Units that support a sustainable operation, and offer the precise temperature controls needed to avoid spoilage or thermal damage – while also safeguarding product quality.

Manufactured in the USA, the Thermo King SG-5000 is a powerful generator set for **marine reefers** that offers a rich mix of performance, low running costs, and no-compromise load protection.

Benefitting from a highly reliable and efficient power source, this premium genset is also **full life CARB compliant**. Available in both clip-on and undermount formats, the SG-5000 is designed to power all ISO reefers on the market.

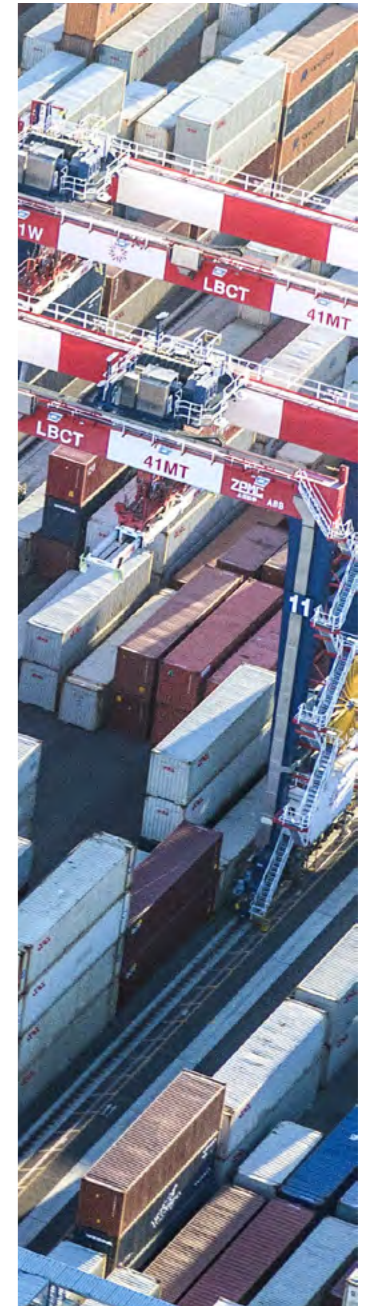

| | |
|--|--------------|
| TRUE RELIABILITY Delivered via a proven, high performance engine and a generator built for stability. | P. 4 |
| LIFELONG COMPLIANCE Fully CARB and EPA compliant for the lifetime of the product to help simplify fleet management. | P. 6 |
| TOTAL COST OF OWNERSHIP The modular design maximizes operational efficiency while helping lower lifetime maintenance costs. | P. 8 |
| INTELLIGENT OPERATION With an advanced controller that combines simple, easy to use navigation with advanced diagnostics. | P. 9 |
| CONFIGURATIONS & SPECIFICATIONS Including both clip-on and undermount options, the SG-5000 offers solutions for a variety of different applications. | P. 10 |

New capabilities, improved reliability

Featuring a proven ultra-powerful engine and high specification generator, the SG-5000 can be uniquely trusted to deliver certainty of operation. In fact, this complete genset incorporates a wide variety of innovations and upgraded components to ensure its position as the most dependable refrigerated power supply available for reefer units.

A GENERATOR DESIGNED FOR EFFICIENCY

The SG-5000 incorporates a large diameter alternator with reinforced bearings and high specification rotating diodes. Plus there's an engine-driven coolant fan and premium corrosion protection to ensure fail-safe operations 24/7.

- Ultra tough 190mm synchronous 4-poles alternator with brushless exciter
- Lower duty cycles (compared to 120mm/145mm models) increase durability and longevity
- Stable voltage control, through an intelligent digital regulator

| | |
|---|---|
| ENGINE TYPE | High Pressure Common Rail (cast iron) |
| POWER | 22kw – delivering 15kw as per ISO standards, with additional power for use in extreme conditions to provide extra load protection |
| POWER ADVANTAGE OVER COMPETITION | 16% |
| OPERATIONAL DURATION | 25,000 hours (with normal maintenance) |
| TESTED TO WORK | -40°C and 50°C, and up to 3,000 meters altitude |
| AUTO RESTART | to provide maximum load protection |
| HIGH TORQUE ADVANTAGE | ensures energy is consistently available under any load conditions |
| SIMPLIFIED MAINTENANCE | no turbocharger or related components |
| WATER SEPARATION SYSTEM | reduces the risk of water returning to the fuel tanks |
| IMPROVED FUEL FILTRATION | delivers a 10x improvement in fuel quality to injectors |





“One solution is all that’s needed to address any load, any customer, and any location”

Getting and staying compliance ready

Reducing emissions throughout the cold chain is obviously an important and worthwhile objective. The challenge comes from ensuring all units meet local and regional standards. Get this right and you can align the right assets to the right journey, maximize fleet utilization, and avoid the cost of expensive retrofits.

ACHIEVE LIFETIME CARB COMPLIANCE

But with the SG-5000, you have a genset that is CARB compliant for the lifetime of the product. As a result you can focus making the most of current and future operations:

- Being lifetime compliant means you won’t have to sell the unit after a few years when it fails compliance testing
- The SG5000 also removes the need for retrofitting an emissions system to ensure compliance
- Lifetime compliance also removes the burden of relocating older units to operational zones outside of California

MAINTAIN FULL EPA TIER 4 COMPLIANCE

Tier 4 compliance standards for off-highway diesel engines are the strictest emissions requirement currently listed by the Environmental Protection Agency (EPA). The regulation is particularly focused on particulate matter and nitrogen oxide emissions, and was fully implemented in 2015. As with the CARB regulations, Thermo King’s SG-5000 enables lifetime compliance with EPA Tier 4.

Transforming your total cost of ownership

Talking TCO with the SG-5000 starts with the value of lifetime compliance, which removes the need to relocate older units outside of California to avoid the potential for non-compliance.

CLIP-ON

The self-contained unit clips on to the corner castings with quick-disconnect fasteners or an optional header pin mounting.

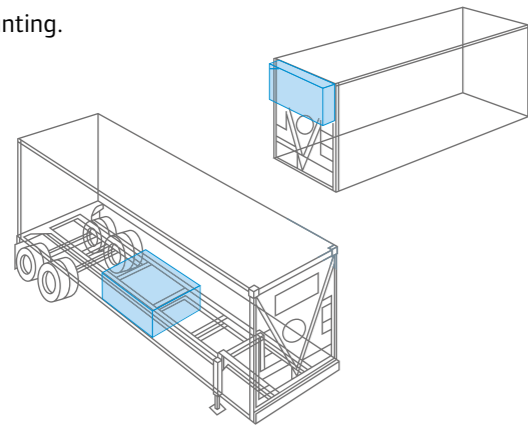

UNDERMOUNT

The undermount SG can be fitted in two ways, to suit the specific needs of the operator.

A HOST OF PRACTICAL BENEFITS

With clip-on and undermount options the SG-5000 can connect to any reefer your fleet possesses and offers maximum operational flexibility:

- **Clip on corner castings**
enhances operational efficiency and ease of use
- **Common components**
drive down costs and improve ease of service
- **Accessible undermount unit**
lowers service and maintenance costs



SUPPORT WHEN YOU NEED IT MOST

Supporting your TCO calculation is the world-class service and parts support available from Thermo King's international dealer network.

Dealers that are:

- Extensively trained
- Highly experienced
- Certified to exacting Thermo King standards

THE SG-5000 UP AND DOWN REPORT



HIGHER EFFICIENCY

- **More fuel efficient engine**
with faster throttle response
- **Eco power as standard**
with integrated 2-speed fuel saving technology
- **Extended service intervals**
stretching to 3,000 hours for scheduled maintenance



LOWER WEIGHT

- **clip-on configuration**
828kg
- **undermount configuration**
686 kg



Monitor and respond to conditions with confidence

With an advanced controller, the SG-5000 offers the **intelligence and control** to safeguard loads across any journey and ambient conditions. From accessing alarms to monitoring temperatures, the genset offers **easy-to-use interfaces** and intuitive management capabilities.

USER-FRIENDLY DISPLAY

- Backlit LCD digital display screen
- Simple, sturdy navigation keypad
- Multi-language capabilities, with English and Spanish languages as standard

SMART DIAGNOSTICS

- Automated pre-trip testing
- Advanced self-check features, including alarms
- Data logging of events, alarms, and messages
- Hardware enabled to support 3rd party telematics

SIMPLE DESIGN

- Manual test functionality
- Built-in battery charger
- HMI separate from control box

TELEMATICS

- Real-time monitoring and management on rail, by road or at terminal
- Optional fuel sensor – works even if the Genset is off
- Factory mounted installation (can retrofit Gensets already in the field)
- Easy and seamless interface with 3rd party systems

Configurations & specifications

CONFIGURATIONS



CLIP-ON
The self-contained unit clips on to the corner castings with quick- disconnect fasteners or an optional header pin mounting.



UNDERMOUNT
The undermount SG can be fitted in two ways, to suit the specific needs of the operator.

SPECIFICATIONS

| | |
|---------------------------|---|
| ENGINE | TK diesel engine compliant with EPA Tier 4 and CARB regulations |
| FUEL TYPE | No. 2 diesel (under normal conditions) No. 1 diesel (cold weather fuel) |
| ROTATIONAL SPEED | 500 ±25rpm / 1800 ±25rpm |
| GENERATOR | 460/230Vac, 3Phase, 60Hz |
| OUTPUT POWER | 15kW |
| APPARENT POWER | 18.75 kVA |
| ROTATIONAL SPEED | 1800rpm |
| ELECTRICAL SYSTEM | SG+ microprocessor controller |
| BATTERY | 12V, 925CCA |
| FUEL TANK | Included in all models |
| SGCO | 473l (125gal) |
| SGCM | 302l or 198l (80gal or 50gal) |
| SGSM | 302l or 198l (80gal or 50gal) |
| WEIGHT - LESS FUEL | |
| SGCO | 871kg (1920lbs) |
| SGCM | 653kg (1440lbs) 50gal tank 680kg (1500lbs) 80gal tank |

DIMENSIONS

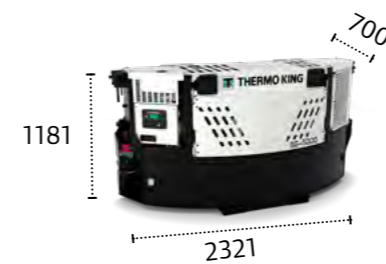

Dimensions in millimeters



THERMO KING

Thermo King – by Trane Technologies (NYSE: TT), a global climate innovator – is a worldwide leader in sustainable transport temperature control solutions. Thermo King has been providing transport temperature control solutions for a variety of applications, including trailers, truck bodies, buses, air, shipboard containers and railway cars since 1938.

For further information, please visit:
thermoking.com

Find your nearest dealer on
dealers.thermoking.com

TRANE
TECHNOLOGIES