

T-1090 & T-1090 MAX SPECIFICATIONS

T-90 SERIES... EXPECT MORE.

Since 1938, Thermo King's priority has been to develop innovative products that meet and exceed the ever changing needs of our customers.

The development of the T-90 Series of transport refrigeration units for straight trucks continues the legacy of customer-focused innovation. Taking our self-powered truck refrigeration models to a new level, the next-generation T-90 Series offers the right solutions for today's challenges. Whether you're looking for more capacity, trustworthy reliability and performance, fuel efficiency, unprecedented temperature pull-down and recovery, convenient maintenance intervals, or all of the above, the T-90 Series will not let you down. And now with the integration of our ConnectedSuite™ telematics package and the standardization of our premium HMI included, you truly get MORE WITH THERMO KING.



KEY OPTIONS

Customize your unit to fit your business needs:

- SmartPower™ Electric Standby (230V and 460V)
- Whisper® Noise Reduction
- Top Screen
- Snow Cover
- Solar panels (40W and 110W options)
- Electronic Door Switches
- Body Mount HMI
- TouchPrint Premium
- PTC - Precision Temp Control
- Arctic Package
- Monitor Package
- Premium Package

SYSTEM PERFORMANCE

Refrigeration capacity: System net cooling capacity at 100°F ambient temperature and high speed engine/60 Hertz electric power

Return air to evaporator	T-1090			T-1090 MAX		
	35°F	0°F	-20°F	35°F	0°F	-20°F
Engine power BTU/hr (Up to)	32,000	21,000	13,500	35,000	22,500	14,250
Electric power BTU/hr (Up to)	27,000	15,500	11,000	28,500	19,000	13,000
Heating capacity (35°F/0°F ambient)						
Engine power (BTU/hr)	14,000			20,000		
Electric power (BTU/hr)	14,000			14,000		
Airflow: on high speed engine operation						
Airflow volume @ 0 Pa static pressure	1,800 ft ³ /min			1,800 ft ³ /min		
Weight (Condensing Unit):						
Standard: cooling/heating on engine operation	1,014 lbs			1,051 lbs		
With SmartPower electric standby: cooling/heating on engine/electric standby	1,123 lbs			1,160 lbs		
Engine: 3 cylinder, liquid cooled						
Model	TK 380			TK 380		
Rating	19.3 hp			19.3 hp		
Maintenance Interval	2000 hrs			2000 hrs		
Compressor: lightweight aluminum alloy						
Model	X-430			X-430		
Displacement	30 cu. in.			30 cu. in.		
Electric standby motor (option1)						
Voltage / phase / cycles	200 - 230 / 3 / 60			200 - 230 / 3 / 60		
Rating	12 hp			12 hp		
Electric standby motor (option2)						
Voltage / phase / cycles	460 / 3 / 60			460 / 3 / 60		
Rating	12 hp			12 hp		
Refrigerants: R-452A zero Ozone Depletion Potential (ODP), internationally approved						
Charge	6.3 lbs			7.5 lbs		

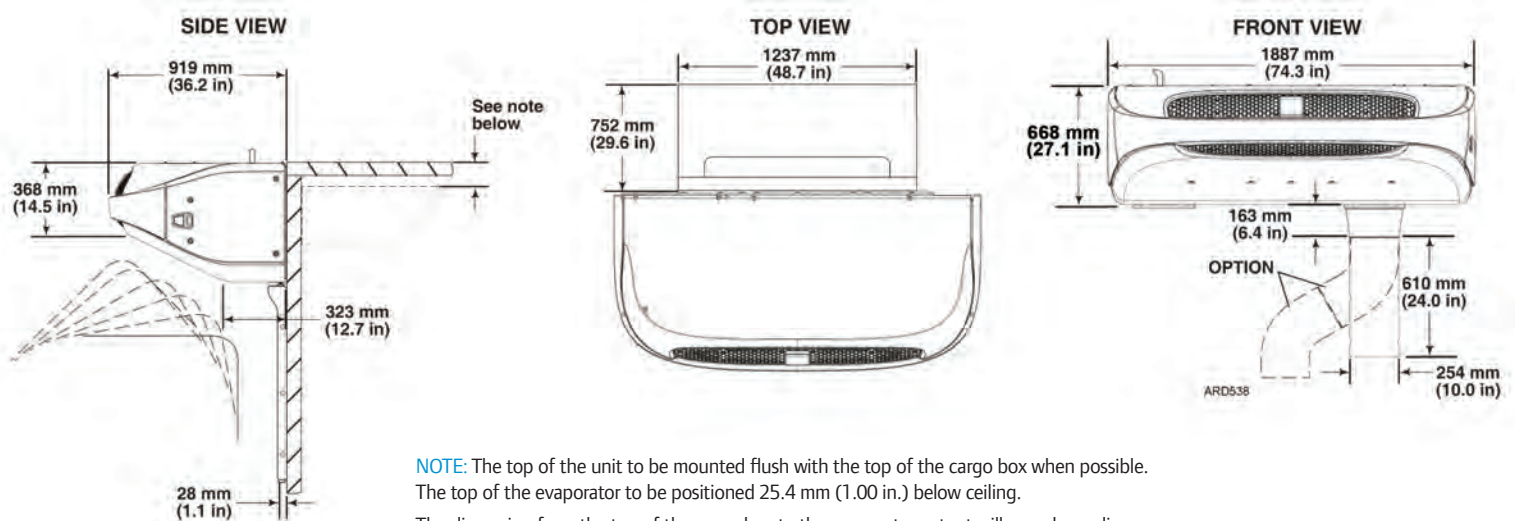

NOTE: The top of the unit to be mounted flush with the top of the cargo box when possible. The top of the evaporator to be positioned 25.4 mm (1.00 in.) below ceiling. The dimension from the top of the cargo box to the evaporator cutout will vary depending on the type of box, truck cab tilt clearance, etc.